



**Model Number**

**UC400-F77-IU-IO-0,2M-V1**

Single head system

**Features**

- IO-Link interface for parameterization
- Programmable via DTM with PACTWARE
- Selectable sound lobe width
- Synchronization options
- Temperature compensation
- Analog output

**Diagrams**

**Characteristic response curve**

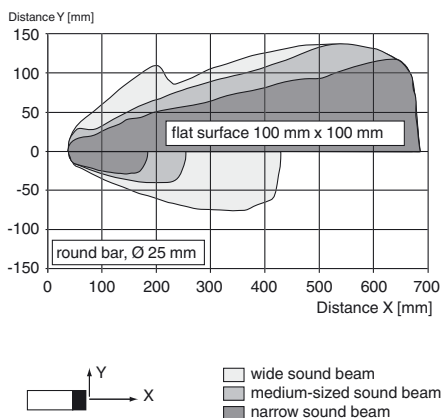

Release date: 2018-07-25 15:49 Date of issue: 2018-07-25 266632-100001\_eng.xml

**Technical data**

**General specifications**

Sensing range	30 ... 400 mm
Adjustment range	40 ... 400 mm
Dead band	0 ... 30 mm
Standard target plate	20 mm x 20 mm
Transducer frequency	approx. 310 kHz
Response delay	minimum : 10 ms factory setting: 37 ms
Sensor cycle time	≥ 10 ms (factory setting) ; programmable to 60 s

**Memory**

Non-volatile memory	EEPROM
Write cycles	300000

**Indicators/operating means**

LED green	solid: power on flashing: standby mode or IO-Link communication
LED yellow	solid: object in evaluation range flashing: programming of the limits, object detected
LED red	solid: fault flashing: programming limits, object not detected

**Electrical specifications**

Operating voltage $U_B$	18 ... 30 V DC , ripple 10 % <sub>SS</sub>
No-load supply current $I_0$	≤ 50 mA
Power consumption $P_0$	≤ 500 mW
Time delay before availability $t_v$	≤ 300 ms

**Interface**

Interface type	IO-Link (after individual activation via programming button)
----------------	--

**Input/Output**

Input/output type	1 synchronization connection, bidirectional
0 Level	0 ... 1 V
1 Level	2.5 V ... $U_B$
Input impedance	> 22 kΩ
Output rated operating current	current sink < 35 mA
Pulse length	≥ 1 ms with external control, low active
Synchronization frequency	
Common mode operation	≤ 109 Hz
Multiplex operation	≤ 109 Hz / n , n = number of sensors , n ≤ 10

**Output**

Output type	1 analog output 0 (4) ... 20 mA or 1 analog output 0 ... 10 V
Resolution	current output: evaluation range [mm]/3200 but ≥ 0.35 mm voltage output: evaluation range [mm]/4000 but ≥ 0.35 mm
Deviation of the characteristic curve	≤ ± 1 % of full-scale value
Repeat accuracy	≤ ± 0.1 % of full-scale value
Load impedance	current output: ≤ 500 Ohm voltage output: ≥ 1000 Ohm
Temperature influence	≤ ± 0.75 % of the end value (with temperature compensation) from 10 minutes after switching on the sensor ; 0,17 %/K (without temperature compensation)

**Ambient conditions**

Ambient temperature	current output -25 ... 60 °C (-13 ... 140 °F) voltage output -25 ... 70 °C (-13 ... 158 °F)
Storage temperature	-40 ... 85 °C (-40 ... 185 °F)

**Mechanical specifications**

Connection type	Cable connector M12 x 1 , 4-pin , L = 200 mm
Degree of protection	IP67
Material	
Housing	Polycarbonate
Transducer	epoxy resin/hollow glass sphere mixture; polyurethane foam
Installation position	any position
Mass	20.5 g
Tightening torque, fastening screws	max. 0.2 Nm

**Factory settings**

Output	near limit: 40 mm far limit: 400 mm Output mode: rising ramp output type: 4 ... 20 mA
Beam width	wide

**Compliance with standards and directives**

Standard conformity	
Standards	EN 60947-5-2:2007+A1:2012 IEC 60947-5-2:2007 + A1:2012 EN 60947-5-7:2003 IEC 60947-5-7:2003

**Approvals and certificates**

UL approval	cULus Listed, Class 2 Power Source
CCC approval	CCC approval / marking not required for products rated ≤36 V

**Dimensions**

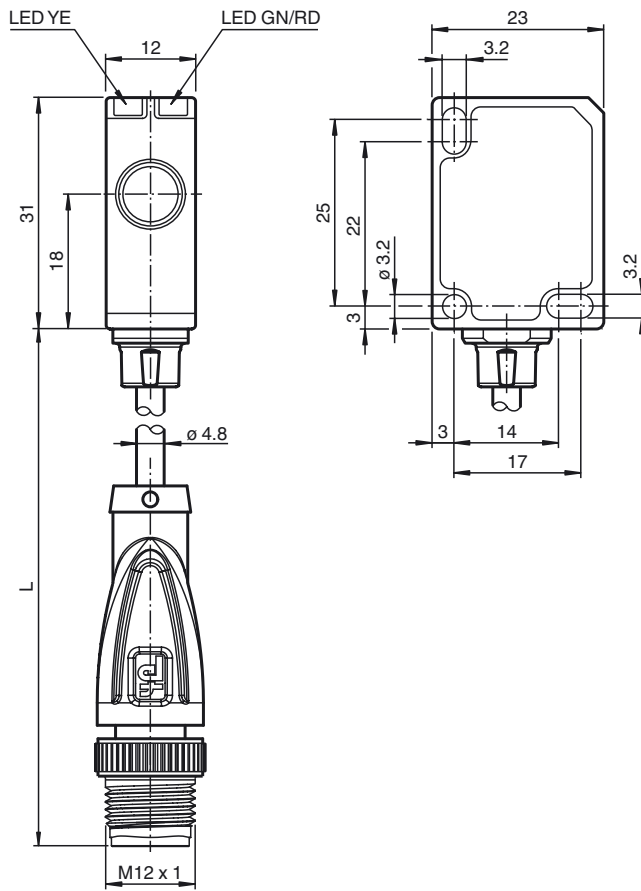

**Additional Information**

**Analog output modes**

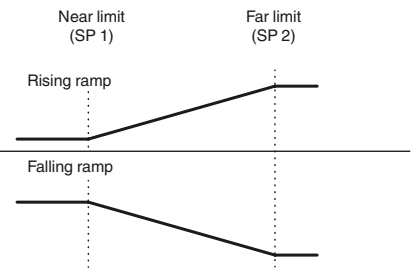

**Electrical Connection**

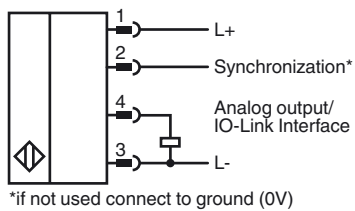

**Pinout**

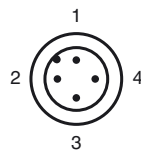

Wire colors in accordance with EN 60947-5-2

1	BN	(brown)
2	WH	(white)
3	BU	(blue)
4	BK	(black)

### Accessories

#### IO-Link-Master02-USB

IO-Link master, supply via USB port or separate power supply, LED indicators, M12 plug for sensor connection

#### V15-G-2M-PVC

Female cordset, M12, 5-pin, PVC cable

#### V1-G-1M-PVC-V1-G

Connecting cable, M12 to M12, PVC cable 4-pin

#### OMH-ML7-01

Mounting aid for ML7 and ML8 series, Mounting bracket

#### OMH-ML7-02

Mounting aid for ML7 and ML8 series, Mounting bracket

### Description of Sensor Functions

#### Adjustment possibilities

The sensor features an analog output with 2 programmable limits. Programming the limits, the output mode, the output type and the beam width can be done in two different ways:

- Using the sensor's programming button
- Using the IO-link interface of the sensor. This method requires an IO-link master (e.g. IO-link-Master02-USB) and the associated software. The download link is available on the product page for the sensor at [www.pepperl-fuchs.de](http://www.pepperl-fuchs.de)

#### Synchronization

The sensor features a synchronization input for suppressing ultrasonic mutual interference („cross talk“).

The following synchronization modes are available:

1. Automatic multiplex mode.
2. Automatic common mode
3. Externally controlled synchronization

#### Further Documentation

- For information on programming via programming button and synchronisation you may refer to the commissioning instruction.
- For detailed information on application and programming via IO-Link we provide a manual.